



WITTENSTEIN

cyber motor

Servo drive system for
automated guided vehicles
cyber® iTAS® system 2

simple
reliable
compact



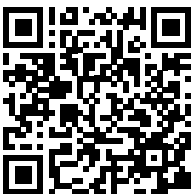

**Catalogs, CAD data and operating manuals can
be found in our download center at**

<https://cyber-motor.wittenstein.de/en-en/download/>

Contents

The Group	4
WITTENSTEIN cyber motor	6
cyber® iTAS® system 2	8
Makes everything simple.	8
Differential drive for AGVs and AMR	10
Connective at all levels	12
Solutions for complex motion tasks	14
Comparison of cyber® iTAS® system 1 and 2	16
cyber® TAS actuator 2 – actuator.....	18
Technical data	20
Options	22
cyber® simco® line – servo drives	24
Technical data	26
Cables	28
Information	36
Ordering code	36
Service concept	40
Drive selection and sizing	42
Commissioning and maintenance	43
Glossary	44

GROUP



WITTENSTEIN

alpha

WITTENSTEIN alpha GmbH
High-precision servo drives and
linear systems



WITTENSTEIN alpha develops, produces and sells mechanical and mechatronic servo drive systems for sectors that require maximum precision. Our products continue to set new standards around the world.

We have divided our product portfolio into four segments in order to meet varying, application-specific requirements: While the Premium and Advanced segments focus on technology and performance, the Value and Basic segments place more emphasis on price and satisfying basic customer requirements.



WITTENSTEIN

cyber motor

WITTENSTEIN cyber motor GmbH
Highly dynamic servo motors and
drive electronics



WITTENSTEIN cyber motor develops, produces and sells technologically advanced servo motors with sophisticated drive electronics as well as complete mechatronic drive systems with maximum power density. Our particular expertise lies in specialized motors for ultra-high vacuums, radioactive environments and high temperatures.

We collaborate closely with our customers on individual projects. During the development process, we share knowledge, learn from one another and develop new ideas together. The resulting solutions help differentiate our customers from their competitors.



WITTENSTEIN

galaxie

WITTENSTEIN galaxie GmbH
Superior gearboxes and drive systems



WITTENSTEIN galaxie develops, produces and sells radically innovative gearboxes and drive systems, whose functional superiority is based on an entirely new operating principle. Our unique expertise makes us the global leader in rotary mechatronic drive technologies.

Our innovations enable our customers to implement their machines and systems with previously unattainable performance parameters. Moreover, our solutions allow products to be manufactured in an efficient way that conserves resources.



WITTENSTEIN motion control GmbH
Drive systems for the most extreme
environmental requirements



WITTENSTEIN motion control develops, produces and sells customized systems for critical environmental conditions using servo motors, gearboxes, electronics and software. Our development expertise and the high level of vertical integration of the components ensure that our technologies meet our customers' requirements.

We focus our innovative solutions on fields that rely on maximum performance, robustness and reliability: Real-time security software completes our product portfolio.



attocube systems
Nanoprecision drive and measurement
technology solutions



attocube develops, produces and sells drive and measurement technology for highly demanding nanotech applications. Its product range includes everything from nano drives and complete microscope systems to innovative sensor solutions, which far exceed current measurement technology in their precision, speed and compactness and can also be used under extreme conditions.

Years of experience and expertise in both the scientific and industrial market segments have yielded an inspiring product catalog boasting maximum precision and user-friendliness. This superior technology revolutionizes existing applications and guarantees lasting competitive advantages for our customers.



baramundi software GmbH
Secure management of the
IT infrastructure in offices and
production



baramundi provides companies and organizations worldwide with efficient, secure and cross-platform management of networked endpoints in IT and manufacturing. The Management Suite provides our customers with integrated, future-orientated unified endpoint management.

baramundi leads the way in regard to unified endpoint management in networked production environments. We develop this solution in close cooperation with the WITTENSTEIN Digitalization Center.

Comprehensive product expertise

- Rotary and linear servo motors and servo actuators
- Drive electronics
- Mechatronic drive systems

Customized solutions

- Customized solutions with maximum customer benefits
- We act holistically and are eager to explore new possibilities
- From conception and development, production and qualification all the way to series delivery

Development and production in Germany

- Strong development team with profound expertise
- High level of vertical integration, including in-house winding room and certified test benches
- Premium quality based on innovative, controllable processes

Servo motors



Drive electronics

WITTENSTEIN – Products that know no limits

Packaging



Pharmaceuticals and food



Assembly and measurement technology



Handling and robotics



Our core competencies

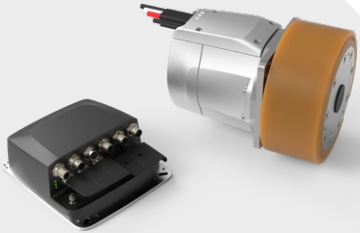

Mechatronic systems



Competent project management

- Preparation of feasibility studies for complex motion tasks
- Defined product development process supervised by certified project managers
- Certified according to DIN EN ISO 9001

From standard industry to harsh environmental conditions

- High and low temperatures
- Radioactivity
- Vacuum
- Pressure
- Explosive atmospheres
- Clean room

Testing, approval and certification

- CE
- UL
- IECEx (ATEX)
- EHEDG

Intralogistics

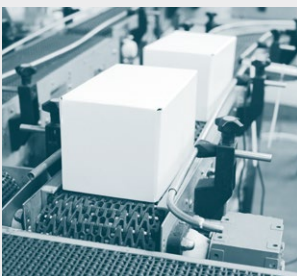

Semiconductor/Electronics production

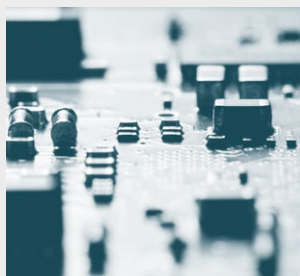

Electromobility



Oil and gas exploration



Makes everything
simple.

cyber[®] iTAS[®] system 2 –
the drive system for AGVs.



Safety

New safety architecture simplifies
vehicle concept and collaborative use
with humans

Connectivity

Wide range of interfaces allows easy
connection to controller infrastructure



Performance

Drive system enables higher productivity as well as smooth slow speed



Flat design

Compact drives for a narrow and flat vehicle design

Service

Smart drive architecture reduces effort from design to operation



cyber[®] iTAS[®] system 2

Differential drive for AGVs and AMR

The drive system at a glance

The drive system, consisting of a servo drive and actuator, combines a lean and integration-friendly safety architecture with maximum power density. This gives

the AGVs (Automated Guided Vehicles) and AMRs (Autonomous Mobile Robots) between 1 and 3 tons a decisive gain in performance and increases productivity.

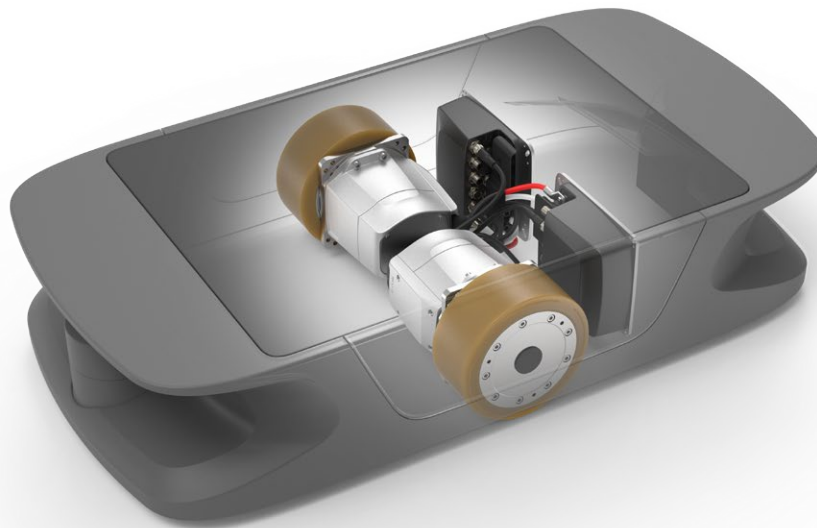

Actuator – cyber® TAS actuator 2

The cyber® TAS actuator 2 offers a support load of 750 kg per wheel – with an overall height of only 180 mm. By integrating the gearbox into the wheel geometry and integrating a space-saving safety encoder, the actuator achieves an overall length of just 230 mm.



Servo drive – cyber® simco® drive 2

The cyber® simco® drive 2 series includes servo drives for sine-commutated servo motors in the voltage range from 12 to 60 V_{DC} and a maximum power of up to 10 kW. The servo drives are available as a decentralized version with protection class IP65. The basic version of the servo drives already have a two-channel STO function (Safe Torque Off) to SIL3/PL e. The safety functions SBC (Safe Brake Control) to SIL3/PL e as well as a safe encoder emulation to SIL2/PL d for the safety encoder in the wheel drive can be added as options. This can also be easily implemented via certified, secure communication interfaces and thus makes an important contribution to the next level safety architecture.



Find out more about
the drive system



Servo drive system

Connective at all levels

With its flexible fieldbus interfaces EtherCAT, PROFINET RT / IRT, EtherNet/IP with CIP Sync, Sercos III and CANopen, the servo drives in the cyber® simco® drive 2 series and the cyber® dynamic system compact drive system can be connected to a wide range of control systems.

The multi-Ethernet interface of the cyber® simco® drive 2 servo drive and the cyber® dynamic system compact drive system sets the new benchmark in this market segment. It allows the user to freely choose between the fieldbus variants EtherCAT, PROFINET, EtherNet/IP with CIP Sync and SERCOS III using the same piece of hardware.

This ensures proven, simple and real-time connectivity to a range of different control environments.





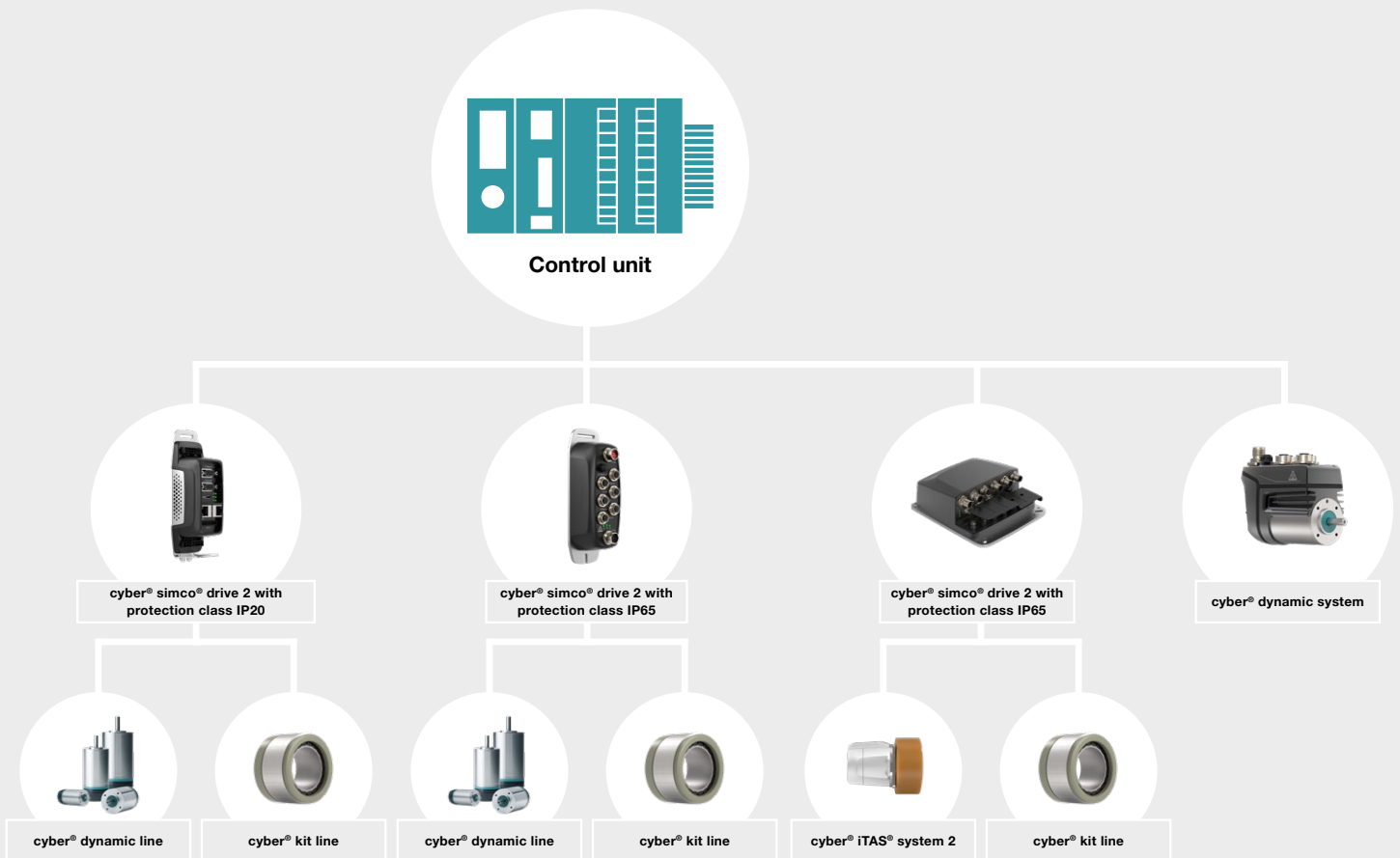

Just one piece of hardware also means just one material number. This means that the unique multi-Ethernet feature reduces the usual number of variants. This, in turn, dispenses with costs and work in terms of electrical construction, procurement, item administration as well as commissioning, service and maintenance.

You also benefit from secure communication interfaces for fast and secure transmission of security-relevant data.



High transmission rates through real-time protocols measurably increase the productivity of the machine.

Fieldbus interfaces

	<ul style="list-style-type: none"> - PROFINET RT/IRT interface supports application classes 1, 3, 4 - Simplest integration into SIEMENS software (TIA portal/ SIMOTION Scout) via the PROFIdrive drive profile - Utilization of all standard technology functions from SIEMENS - Simplest configuration using the GSDML file provided – simplified axis configuration - Deviation of max. 1 µs in the bus cycle with PROFINET IRT
	<ul style="list-style-type: none"> - Industrial drive system for connection to the Rockwell control system - Implementation of different applications with cycle times of up to 1 ms - Simple commissioning and full utilization of the Rockwell control system save time and costs – no additional expertise required - Pre-prepared add-on instructions for implementation of different applications
	<ul style="list-style-type: none"> - EtherCAT (CoE) fieldbus interface for connecting the servo drive to a Beckhoff controller – the parameters used are therefore the same as the CANopen standard - Time-saving and easy to use thanks to File over EtherCAT: load files via the EtherCAT bus from the control system directly to the servo drive. Data can be simultaneously distributed to any number of servo drives in the network, e.g. no additional wiring for firmware updates, use of existing expertise
	<ul style="list-style-type: none"> - The FSP Drive profile allows synchronous motion profiles with low cycle times and jitter to be implemented - The usual axis modules and technology functions of the Schneider Electric control system can be used, making the integration and configuration of the servo drive extremely easy.
	<ul style="list-style-type: none"> - Integration of the servo drive with CANopen according to protocol standard 402 - Implementation of numerous operating modes, e.g. profile position, profile velocity, etc. - Maximum flexibility in process design through dynamic PDO mapping: process data can be changed via dynamic PDO mapping even during operating time
	<ul style="list-style-type: none"> - Parametrization of n-axes via the TCP/IP interface (without connecting each individual simco® drive to a PC) - No wiring required

Safe fieldbus communication

	<ul style="list-style-type: none"> - Safe communication interfaces enable fast and secure transmission of security-relevant data without additional cabling - Certified interfaces according to IEC 61508 to SIL3 and PLe (Performance Level e) Category 4 meet the highest safety requirements - Benefit from reduced time and costs for commissioning, service, documentation for the safe operation of plants and machines
-------------------------------------------------------------------------------------	----------------------------------------------------------------------------------------------------------------------------------------------------------------------------------------------------------------------------------------------------------------------------------------------------------------------------------------------------------------------------------------------------------------------------------------------------------------

Drive system

Solutions for complex motion tasks



Transport with maximum speed and minimum footprint.

Simple.
Safe.
Compact.

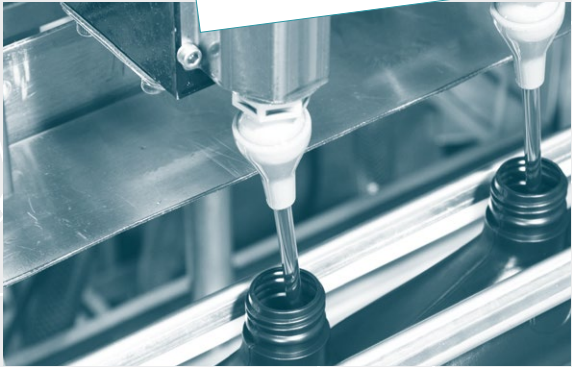



 **Assembly**

High-precision movement with increased safety and precision requirements.



Comparison of cyber[®] iTAS[®] system 1 and 2

Next level safety architecture

cyber[®] iTAS[®] system 1 with basic safety architecture

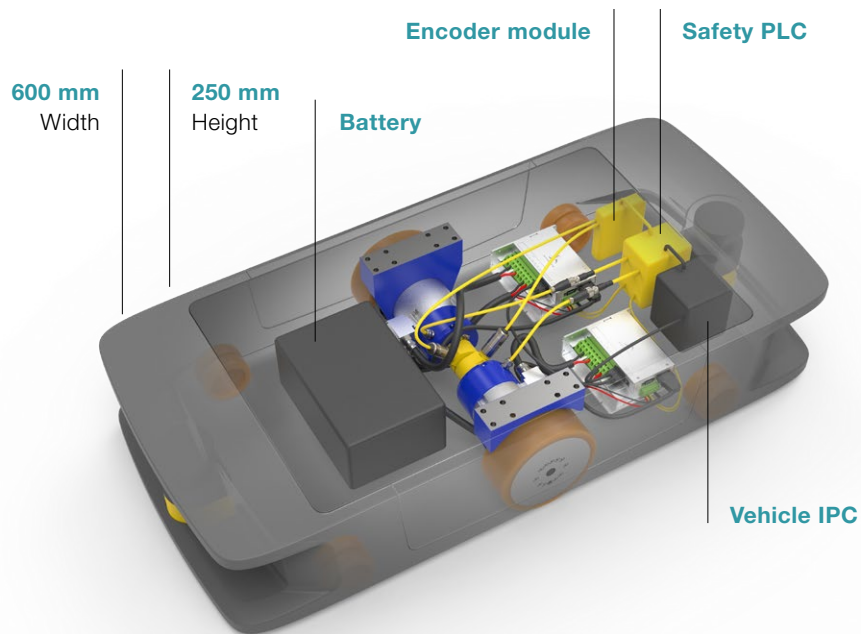

cyber[®] iTAS[®] system 2 with next level safety architecture

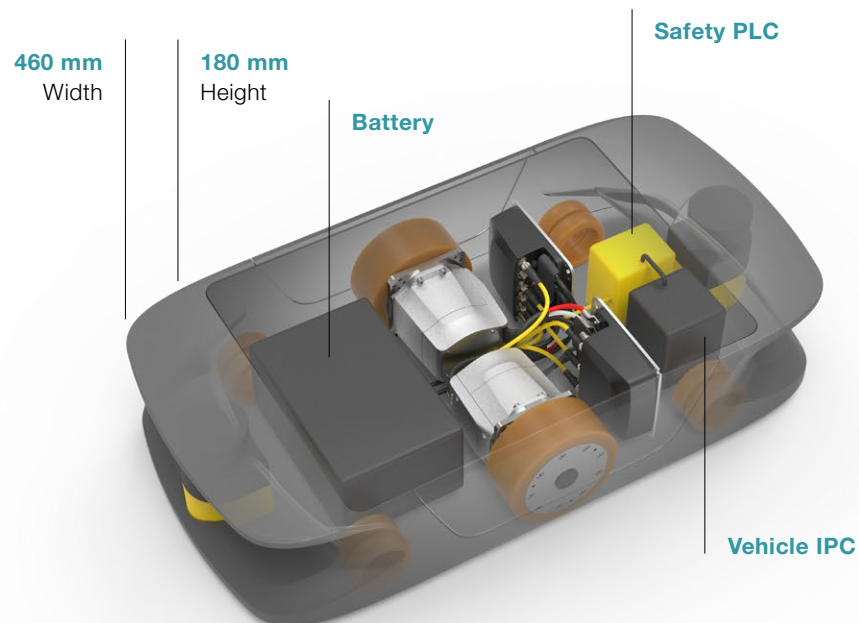

Reduction of components

The integrated safety architecture of the cyber® iTAS® system 2 helps to save on components such as cables, contactors, relays or a second encoder. Fewer components means a lower risk of downtime and less assembly and documentation work, while still meeting the requirements for the safe operation of AGVs and AMRs.

Wide range of safety functions

The basic version of the cyber® simco® drive 2 servo drive already features a two-channel STO function (Safe Torque Off). The safety functions SBC (Safe Brake Control) as well as a safe encoder emulation for the safety encoder in the wheel drive and the safety function SP (Safe Position) can be added as options. Communication via safe bus systems, means that IO modules, various cables, relays and encoder modules can be omitted, while still meeting the highest safety requirements in the AGV and AMR market.

Flat and space-saving design

The compact drive system cyber® iTAS® system 2 requires significantly less installation space. This is thanks to a number of factors including the axial actuator mounting, the single-sided connector arrangement on the servo drive and the integration of the gearbox in the wheel geometry. As a result, very flat vehicles (with a height from 180 mm) and narrow vehicles can be realized.

cyber[®] TAS actuator 2

In-wheel servo actuator

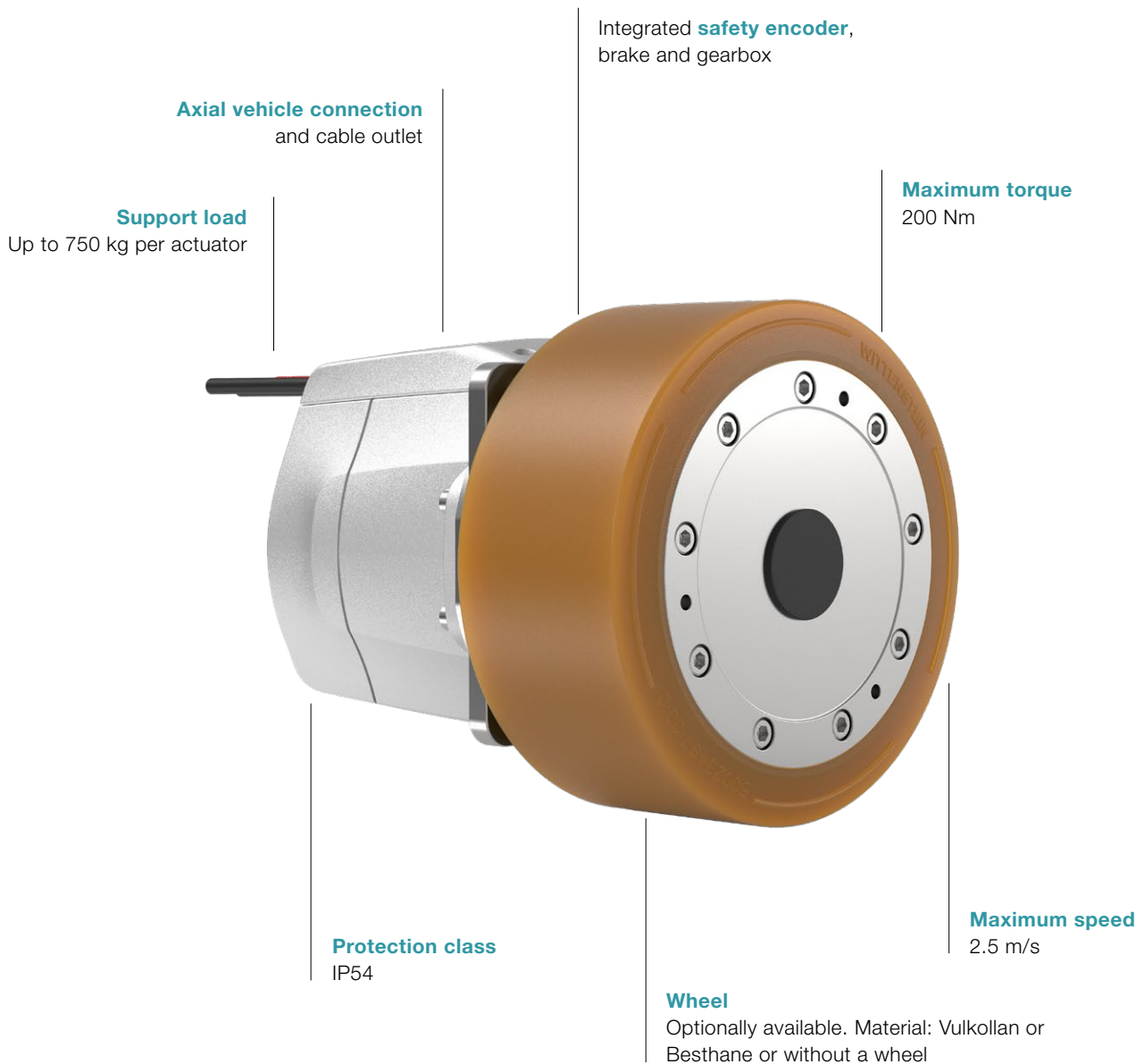

The in-wheel servo actuator cyber[®] TAS actuator 2 is the professional choice for powerful automated guided vehicles (AGV), autonomous mobile robots (AMR) and

other mobile platforms weighing up to 1 to 3 tons. With an integrated safety encoder, brake and gearbox, it offers maximum reliability and safety.

+ Flat design

Maximum design flexibility for vehicles with a height of just 180 mm or more is made possible by axial vehicle mounting and cable outlet.

+ Performance

Maximum performance for vehicles weighing up to 1 and 3 tons – heavy yet fast vehicles can be built even more compactly with the cyber® iTAS® system 2. The support load of 750 kg per wheel allows for shortest braking distances and smaller protective fields.

+ Safety

With its newly designed next level safety architecture, the cyber® iTAS® system 2 meets the high safety requirements through to collaborative deployment scenarios, while at the same time taking performance and productivity requirements into account.

+ Simplicity

The motor parameters of the cyber® TAS actuator 2 are saved in the cyber® simco® drive 2 and automatically called on power-up. This electronic name plate ensures that commissioning is simple, fast and reliable.

cyber[®] TAS actuator 2

IP54

Size			085
DC bus voltage	U_{DC}	V_{DC}	48
Maximum torque	M_{max}	Nm	204
Maximum current	I_{max}	A	130
Continuous stall torque	M_0	Nm	56
Continuous stall current	I_0	A	32
Brake holding torque (at 100°C)	M_4	Nm	70
No-load speed	n_0	rpm	312
Weight	m	kg	15.5 kg
Ambient temperature	ϑ_U	°C	0 up to +40
Protection class		IP	54
Support load per wheel		kg	750
Wheel covering			Besthane / Vulkollan
Shore hardness of wheel covering			92 A

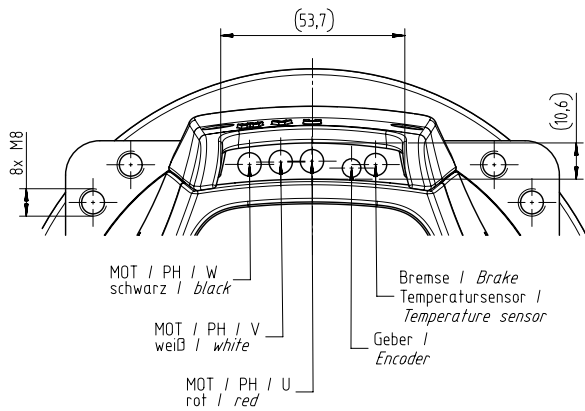
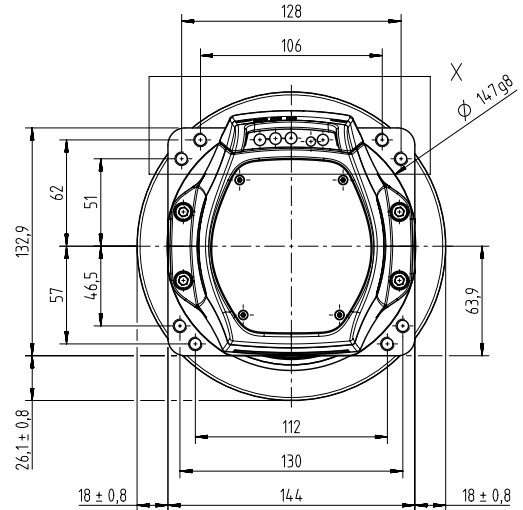
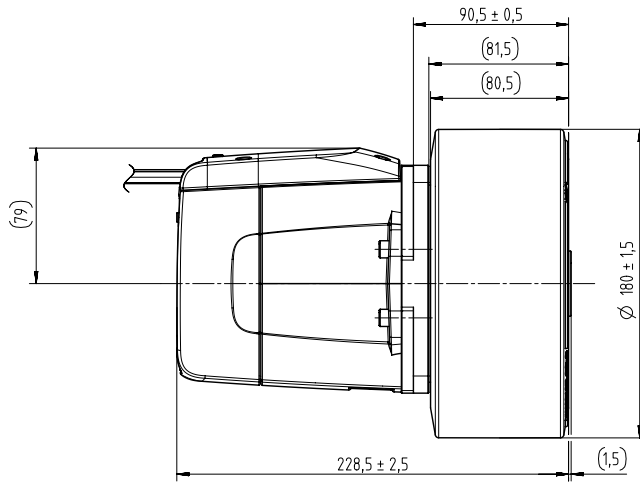

Function	Cable end
MOT / PH / W	M5 ring terminal connector
MOT / PH / V	M5 ring terminal connector
MOT / PH / U	M5 ring terminal connector
Encoder	M12 17-pole, A-coded socket, straight
Brake & temperature sensor	M12 4-pole; A-coded socket, straight

cyber[®] TAS actuator 2

Options

Holding brake

The brakes installed in the drive actuators are electromagnetically actuated dual-surface spring-applied brakes. The braking force is generated by springs and canceled by an electromagnetic force. In a de-energized state, the two friction surfaces are pressed onto countersurfaces by springs, producing a brake torque. By placing voltage on the excitation winding, the magnetic rotor is moved by the resulting force. This movement is directed against the pressure force of the springs. In this way, the friction and counter-surfaces are released from each other, leading to cancellation of the brake torque.

Size	085
Nominal voltage	12 V (±10%)
Rated overexcitation voltage	24 V (±10%)
Rated power	9 W
Overexcitation rating	36 W
Rated current	0.75 A
Overexcitation time	300 ms to 500 ms
Closing time	80 ms
Opening time	110 ms

Encoder

As motor feedback on commutation, a PL d safety encoder with the following technical data is used in the drive actuator:

Encoder	IK
Interface	EnDat 2.2 FS
Position values/U	524288 (19 bit)
System accuracy	± 90"
Supply voltage	DC 3.6 V to 14 V
Functional safety	SIL 2 to EN 61508 Category 3, PL d according to EN ISO 13849-1:2015
PFH	$SIL\ 2 \leq 15 \times 10^{-9}$

cyber[®] simco[®] line

Servo drives

Installation space saving

Up to 30%

Multiple fieldbus interfaces

- Multi-Ethernet capable
- Real-time capable fieldbus interfaces
- Safe fieldbus communication
- Numerous feedback interfaces

Protection class

IP65

Wide range input

12–60 V_{DC}

Integrated safety functions

STO to SIL3 / PL e
SBC to SIL3 / PL e
SP via EnDat FS to SIL3 / PL e
Encoder emulation (SIL2 / PL d)

Electronic name plate

Automatic and safe parametrization
of the motor



In combination with various servo motors and servo actuators, the cyber[®] simco[®] drive 2 is the ideal solution for fast and precise transportation and positioning tasks. With a continuous power of up to 5 kW and a short-term

peak output of 10 kW, the servo drive is suitable for high-precision applications, e.g. in the machine-tool, electronics or packaging industries.

+ Connectivity

The cyber® simco® drive 2 servo drive is available with a multi-EtherNet interface and allows the user to choose freely between the fieldbus variants EtherCAT, PROFINET, EtherNet/IP with CIP Sync and SERCOS III using the same piece of hardware. A variant with CANopen is also available as an option. This feature ensures proven, simple and real-time connectivity to a range of different control environments. The multi-Ethernet version also reduces the usual number of variants and avoids high costs and effort in terms of electrical construction, procurement, item administration as well as commissioning, service and maintenance. You also benefit from safe communication interfaces for fast and secure transmission of security-relevant data without additional cabling.

+ Flexibility

The multi-Ethernet variant in the cyber® simco® drive 2 series offers considerable flexibility when selecting the required interfaces. In addition, various performance classes are available and can be selected to suit the application.

+ Dynamics and precision

Dynamics and precision are two further characteristics that set the cyber® simco® drive servo drives apart. Real-time and isochronous Ethernet communication, a high current resolution of 14 bits and a switching frequency of 16 kHz enable extremely precise torque control in complex motion control applications.

+ Intelligence

cyber® simco® drive "thinks" ahead and for you. Integration, commissioning, operability, configuration, communication: With the cyber® simco® line, everything is designed for simplicity, intuition and efficiency. Automatic motor parameterization thanks to the electronic name plate and the integrated PLC functionality are just two examples of this. This saves time and money – and is more than clever.

+ Safety and robustness

Suitable for industrial use – thanks to the combination of a robust design with integrated safety. The integrated safety function STO (Safe Torque Off) ensures that all drive variants meet safety requirements to SIL3 / PL e. Additional safety functions as well as secure fieldbus interfaces are available with the variant with optional safety card. Moreover, the servo drives feature a 12 to 60 V_{DC} wide range input on the supply side, making them ideal for battery operation. In addition, the servo drives are available with protection class up to IP65 and are therefore also suitable for demanding operating conditions.

+ Compactness and simplicity

The cyber® simco® drive 2 servo drives boast an extremely compact design. This series is around 30% more compact than the predecessor version and allows easy pin assignments as the connection elements are arranged at the front.

cyber[®] simco[®] drive 2

IP65

Performance version		SIM2050	SIM2100
Supply voltage (power / logic / STO)	V_{DC}	+12 to +60	
Rated current	A_{eff}	50	100
Maximum current	A_{eff}	100	200
Rated power (at 48 V_{DC})	W	2500	5000
Maximum power (at 48 V_{DC})	W	5000	10000
Communication	-	EtherCat, PROFINET RT/IRT, EtherNet/IP with CIP Sync, Sercos III, CANopen With safety card: PROFIsafe	
Encoder interface	-	Without safety card: EnDat 2.2, BiSS-C, SSI, Resolver, Sin/Cos encoder, incremental encoder with Hall With safety card: EnDat 2.2 FS	
Commissioning	-	USB	
Digital inputs	-	4	
Digital outputs	-	2	
Safety function	-	Without safety card: STO to SIL 3 With safety card: safe 1 safety V_{SS} sine/cosine encoder emulation to SIL 2, SBC to SIL 3	
Brake control	-	Yes	
Brake chopper	-	Not integrated	
Technology functions	-	Motion Task	
Weight	kg	1.52	
Ambient temperature	°C	0 to 45	
Protection class	IP	65	
Approval	-	NRTL, CE, functional safety	

Find out more about the cyber[®] simco[®] drive
in combination with traction drives for use in
automated guided vehicles



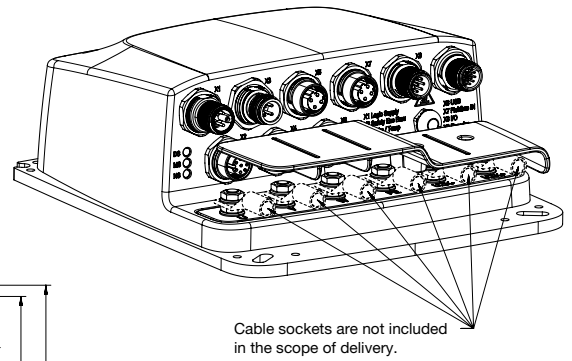
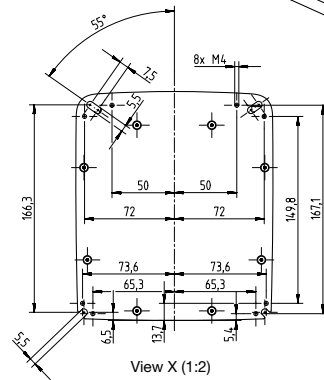
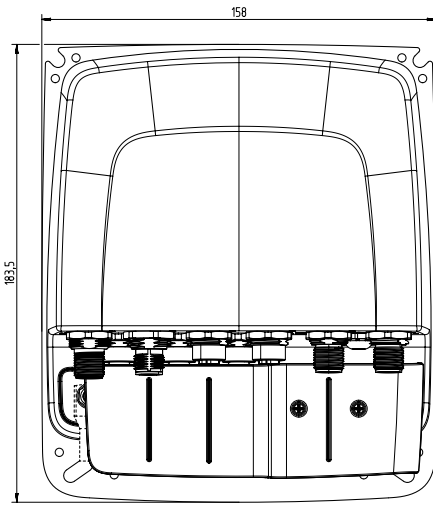
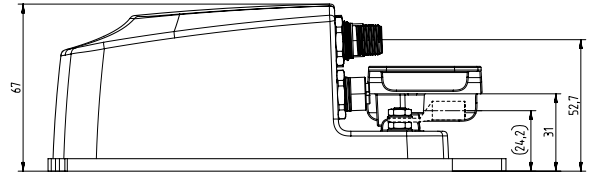
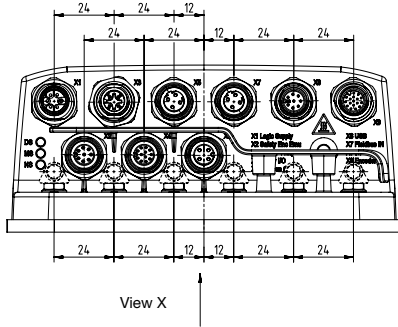

Number	Function	Connector on the device
X1	Power supply (logic / STO)	M12 6-pole connector
X2	Safety encoder emulation	M12 8-pole socket, A-coded
X3	Motor and brake temperature sensor	M12 4-pole connector A-coded
X4	Safety I/O	M12 12-pole socket, A-coded
X5	Fieldbus interface Output	CAN: M12 5-pole socket, A-coded Ethernet-based: M12 4-pole socket, D-coded
X6	Diagnostic interface USB	M12 4-pole socket A-coded
X7	Fieldbus interface Input	CAN: M12 5-pole connector, A-coded Ethernet-based: M12 4-pole socket, D-coded
X8	Digital inputs and outputs	M12 8-pole connector A-coded
X9	Encoder interface	M12 17-pole connector A-coded
	Motor (U, V, W, PE) and power supply (UZK+/UZK-)	M5 threaded connection / M5 cable lug up to 25mm ²

Cables

cyber[®] simco[®] line

1st cyber[®] simco[®] drive

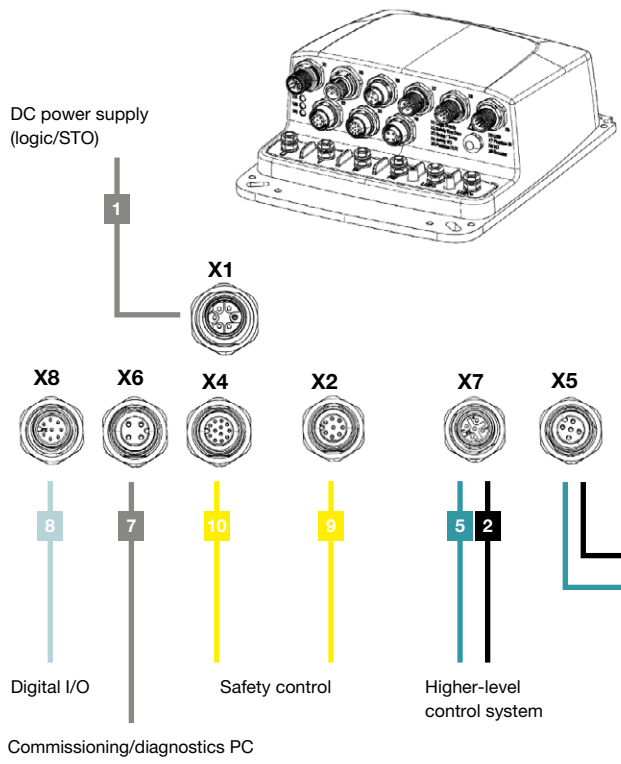

2nd cyber[®] simco[®] drive

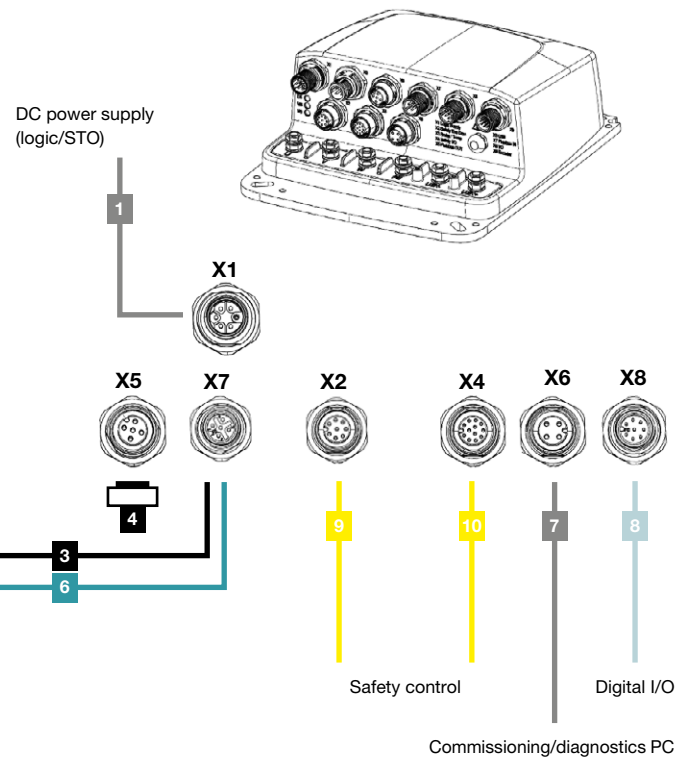

- Digital I/O
- CANopen
- Ethernet-based
- Commissioning
- Safety

IP65

No.	Type of accessory	Description	Interfaces		Description	Standard lengths
			1st simco® drive	PLC/PC/2nd simco® drive		
Power supply (power/STO)						
1	Power supply cable	CAPOWE-M12FSM-FL_-LXXXX	M12 socket 6-pole	Flying leads	DC - Power supply cable	1.5; 3; 5; 10 m
Fieldbus CANopen						
2	Fieldbus cable PLC	CAB-BUS-CAN-M12M-FL_-LXXXX	M12 socket 5-pole A-coded	Flying leads	Network connection to PLC; plug can be assembled	1; 2; 5; 10; 15 m
3	Fieldbus cable extension	CASIGN-CAN-M12FSA-M12MSA-LXXXX	M12 connector 5-pole A-coded	M12 socket 5-pole A-coded	Network connection between simco® drives	1; 2; 5; 10; 15 m
4	Terminating resistor CANopen	CAB-BUS-CAN-M12M-TERMINAT	-	M12 connector 5-pole A-coded	Only necessary for CAN communication	-
Industrial Ethernet (EtherCAT / PROFINET / EtherNet/IP / Sercos III)						
5	Network cable PLC	TCC 002-025-XXXR-PUR	M12 connector 4-pole D-coded	RJ45 connector	Network connection to PLC	1; 2; 5; 10; 15 m
6	Network cable extension	TCC 002-026-XXXR-PUR	M12 connector 4-pole D-coded	M12 connector 4-pole D-coded	Network connection between simco® drives	1; 2; 5; 10; 15 m
Commissioning						
7	USB connection cable	CASIGN M12-4p USB-A 2.0m PVC	M12 plug 4-pole A-coded	USB A connector	Connection cable for diagnostic purposes, commissioning with MotionGUI 2	2 m
Digital in- and outputs						
8	Cable for Digital IO	CASIGN-I/O-M12FSA-M12FSA-L0500	M12 socket 8-pole A-coded	M12 socket 8-pole A-coded	Connection cable to I/O box	5 m
Safety encoder emulation						
9	Cable for safety encoder emulation	CASIGN-SAC-8P-M12MS-PUR-L1500	M12 plug 8-pole A-coded	Flying leads	Connection to safety control; connector can be assembled	1.5 m
Safety I/O						
10	Cable for safety I/O	CASIGN-SAC-12P-M12MS-PUR-L1500	M12 plug 12-pole A-coded	Flying leads	Connection to safety control; connector can be assembled	1.5 m
Encoder						
11	Cable for encoder interface	CASIGN-SAC-17P-M12FS-PUR-LXXXX	M12 socket 17-pole A-coded	Flying leads	Encoder cable to motor; connector can be assembled	1; 3 m
Temperature sensor / brake						
12	Cable for motor/brake temperature sensor	CASIGN-TempBr-M12FSA-FL_-L0100	M12 socket 4-pole A-coded	Flying leads	Temp. sensor / brake cable to motor; connector can be assembled	1 m

XXXX = cable length in cm (example: 5 m = 0500)

XXX = cable length in dm (example: 5 m = 050)

Cables

cyber[®] simco[®] line

IP65

Technical details:

	cyber [®] simco [®] drive power supply cable (No. 1)	Fieldbus cable IP65 (No. 2, 3)	Network cable (No. 5, 6)	USB connection cable IP65 (No. 7)	Cable for Digital IO IP65 (No. 8)
Suitable for drag chains	Max. 2 million cycles	Max. 5 million cycles	Max. 3 million cycles	No	Max. 10 million cycles
Approval	UL listed (E468743)	UL (AWM style 20233/10578), CSA; CE	UL (AWM style 20233/11602), CSA; CE	CE	CE
Outer sheath material	PUR	PUR	PUR	PVC	PUR
Shielding	Yes	Yes	Yes	Yes	No
Temperature range (static)	-25 to +80°C	-40 to +80°C	-40 to +80°C	-30 to +80°C	-25 to +80°C
Temperature range (dynamic)	-25 to +80°C	-30 to +70°C	-30 to +70°C	-5 to +70°C	-25 to +80°C
Min. bending radius (static)	5 × outer-Ø	6 × outer-Ø	5 × outer-Ø	-	5 × outer-Ø
Min. bending radius (dynamic)	10 × outer-Ø	10 × outer-Ø	12 × outer-Ø	-	10 × outer-Ø
Outer diameter	10.4 mm ±0.3 mm	6.9 mm ±5%	6.7 mm ±5%	4.6 mm ± 5%	5.8 mm ±5%
Transmission parameter	-	-	CAT 5, Class D (ISO/IEC 11801:2002), (EN 50173-1)	-	-
Transmission rate	-	-	up to 100 Mbit/s Full Duplex	-	-

	Cable for safety encoder emulation (No. 9)	Cable for safety I/O (No. 10)	Cable for encoder interface (No. 11)	Cable for motor and brake temperature sensor (No. 12)
Suitable for drag chains	Max. 4 million cycles	Max. 4 million cycles	Max. 1 million cycles	No
Approval	CE, UL, CSA, EAC	CE, UL, EAC	CE, UL, CSA	CE, UL, CSA, EAC
Outer sheath material	PUR	PUR	PUR	PVC
Shielding	Yes	No	Yes	Yes
Temperature range (static)	-25 to +80°C	-40 to +80°C	-40 to +80°C	-30 to +80°C
Temperature range (dynamic)	-5 to +80°C	-20 to +80°C	-25 to +80°C	-5 to +80°C
Min. bending radius (static)	5 × outer-Ø	5 × outer-Ø	8 × outer Ø	10 × outer-Ø
Min. bending radius (dynamic)	10 × outer-Ø	10 × outer-Ø	12 × outer Ø	-
Outer diameter	5.9 mm ± 0.2 mm	7.2 mm	8.5 mm ± 0.25 mm	5.3 mm ± 5%
Transmission parameter	-	-	-	-
Transmission rate	-	-	-	-

cyber® simco® drive power supply cable (No. 1)

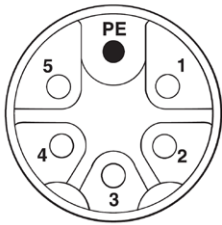

Female,
M-coded

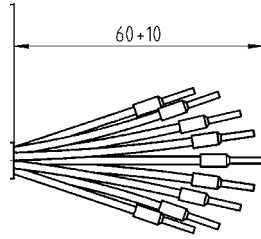

	M12 socket, straight pin assignment	Flying leads labeling
N.C.	1	BK1
N.C.	2	BK2
Logic+	3	BK3
STO	4	BK4
STO GND	5	BK5
FE	6	GN/YE

CANopen fieldbus cable (No. 2)

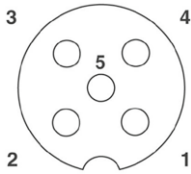

Female,
A-coded

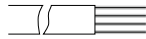

	M12 plug, straight pin assignment	Flying leads color coding
Shield	1	-
+	2	Red
-	3	Black
CAN-H	4	White
CAN-L	5	Blue

CANopen fieldbus cable (No. 3)

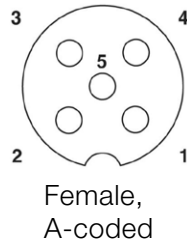
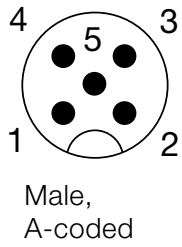

	M12 plug, straight pin assignment	M12 plug, straight pin assignment
Shield	1	1
+	2	2
-	3	3
CAN-H	4	4
CAN-L	5	5

Ethernet network cable (No. 5)

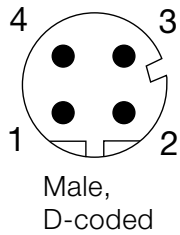

	M12 plug, straight pin assignment	RJ45 plug, straight pin assignment
TD+	1	1
TD-	3	2
RD+	2	3
RD-	4	6

Ethernet network cable (No. 6)

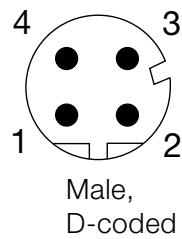
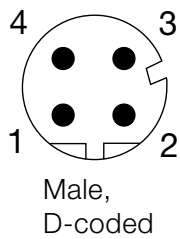

	M12 plug, straight pin assignment	M12 plug, straight pin assignment
TD+	1	1
TD-	3	3
RD+	2	2
RD-	4	4

USB connection cable (No. 7)

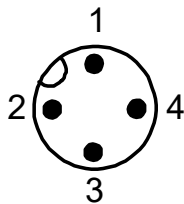

Male,
A-coded

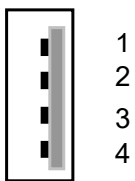

Male

	M12 plug, straight pin assignment	USB-A connector pin assignment
VCC	1	1
D-	2	2
D+	3	3
GND	4	4

Cable for Digital IO (No. 8)

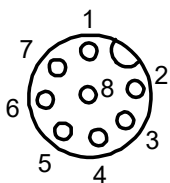

Female,
A-coded

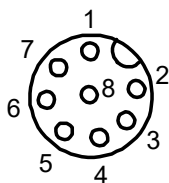

Female,
A-coded

	M12 socket, straight pin assignment	M12 socket, straight pin assignment
DIN 2	1	1
DIN 4	2	2
DOUT 1	3	3
DOUT 2	4	4
VCC24	5	5
DIN 1	6	6
GND	7	7
DIN 3	8	8

Cable for safety encoder emulation (No. 9)

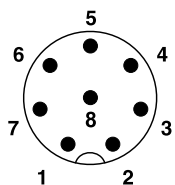

Male,
A-coded

	M12 plug, straight pin assignment	Flying leads color coding
GND	1	White
SIN+	2	Brown
SIN-	3	Green
COS+	4	Yellow
COS-	5	Gray
N.C.	6	Pink
N.C.	7	Blue
N.C.	8	Red

Cables

cyber[®] simco[®] line

Cable for safety I/O (No. 10)

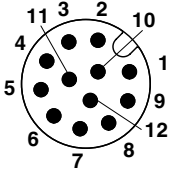

Male,
A-coded

	M12 plug, straight pin assignment	Flying leads color coding
STO_A	1	Brown
STO_B	2	Blue
N.C.	3	White
N.C.	4	Green
N.C.	5	Pink
N.C.	6	Yellow/pink
RESET	7	Black
GND	8	Gray
VCC24	9	Red
DOUT1	10	Violet
DOUT2	11	Gray/pink
N.C.	12	Red/blue

Cable for encoder interface (No. 11)

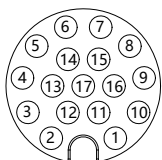

Female,
A-coded

	M12 plug, straight pin assignment	Flying leads color coding
GND RESOLVER REF-	1	Brown
5V3 RESOLVER REF+	2	Blue
CLOCK+INC. A+	3	White
CLOCK-INC. A-	4	Green
DATA+INC. B+	5	Pink
DATA INC. B-	6	Yellow
SIN/COS A+RESOLVER COS+	7	Black
SIN/COS A RESOLVER COS-	8	Gray
SIN/COS B+RESOLVER SIN+	9	Red
SIN/COS B-RESOLVER SIN-	10	Violet
SIN/COS Z+INC. Z+	11	Gray/pink
SIN/COS Z-INC. Z-	12	Red/blue
HALL U	13	White/green
HALL V	14	Brown/green
HALL W	15	White/yellow
N.C.	16	N.C.
N.C.	17	N.C.

Cable for motor and brake temperature sensor (No. 12)

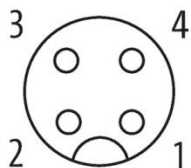

Female,
A-coded

	M12 plug, straight pin assignment	Flying leads color coding
Brake+	1	Brown
Brake-	2	White
Temp_Mot+	3	Black
Temp_Mot-	4	Blue

Information

Ordering code – cyber® TAS actuator 2

Actuator

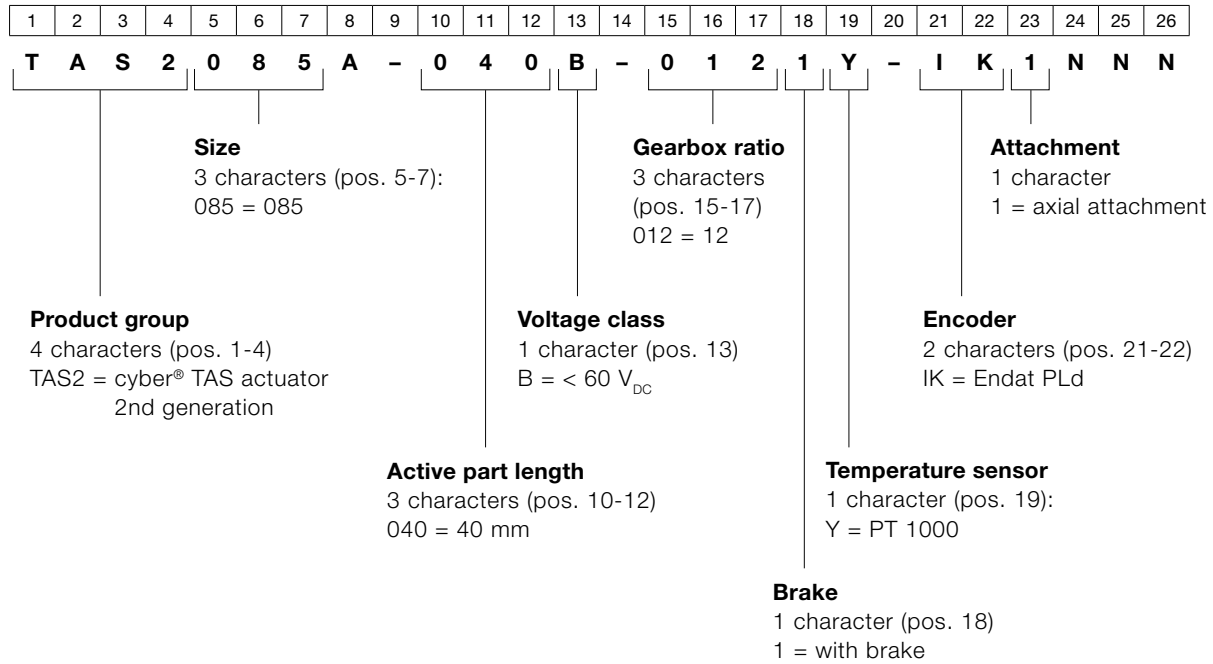

Cable assembly

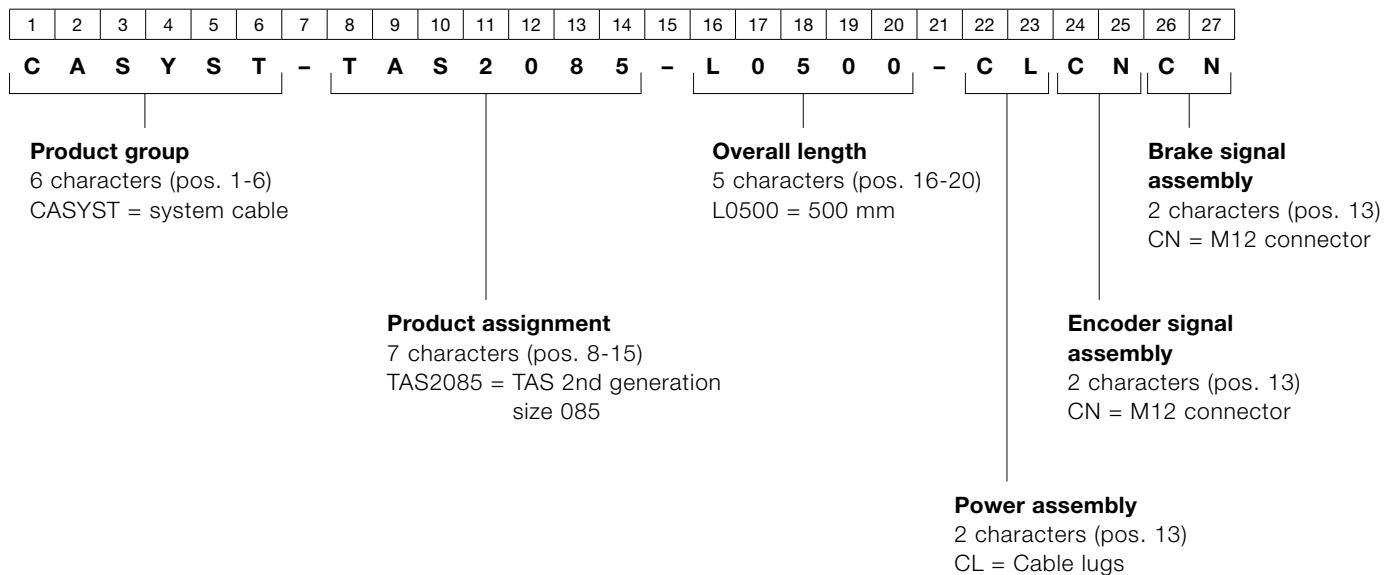

Wheel

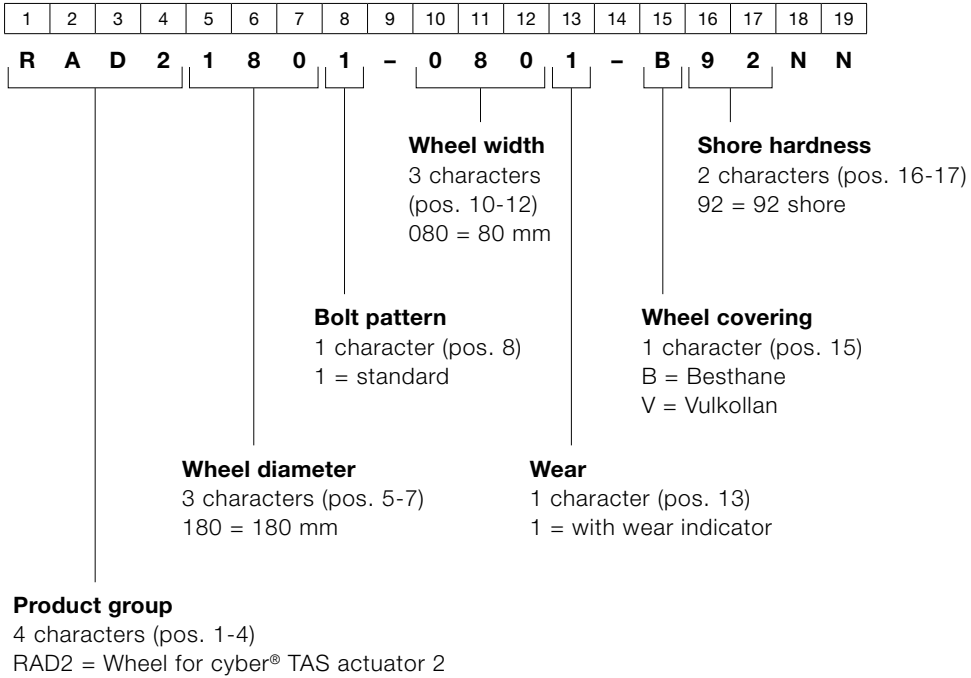

Information

Ordering code

cyber® simco® line 2

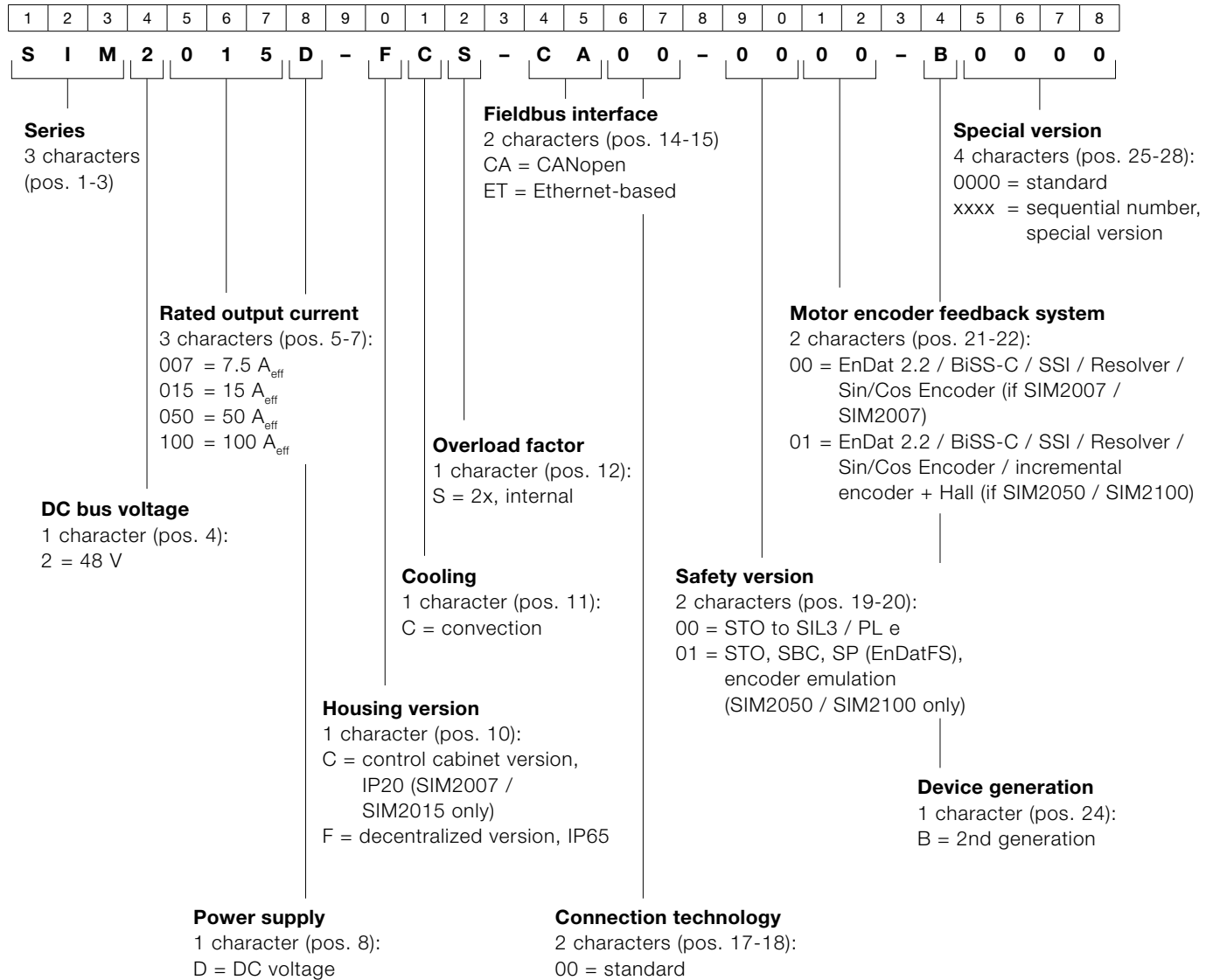

Information

Service concept

PRE-SALES

Planning



Investment



Consulting expertise

- Optimum solutions thanks to professional application calculations and drive sizing
- Customized solutions and maximum innovation

Customer training und webinars

- Tailored content and specific training programs
- Recordings of WITTENSTEIN webinars to enable familiarization with products and solutions

CAD POINT

- Technical data sheets and 3D data – find the right information with just a few clicks

cymex® Optimization of your drive train

- cymex® – the tried-and-tested software for drive system optimization
- cymex® enables straightforward dimensioning and evaluation of the complete drive train (application + transformation + motor + gearbox)
- Support and extensive design experience

Our services at a glance



AFTER-SALES

Usage



Re-investment



Professional support for the best possible start

- Assistance with installation and commissioning
- Individual training in commissioning
- Operating manuals with information regarding commissioning and installation
- Optimum integration of the system in your application

WITTENSTEIN Service Portal

- Support throughout the entire life cycle of your WITTENSTEIN product
- Instant access to individual product information
- Quick assembly and commissioning
- Play IIoT with Smart Services

Maintenance

- Proactive measures to minimize failure risks
- Personal and prompt handling of your time-critical repair requirements
- Tailored repairs combining highest levels of quality and care

Application-specific retrofitting

- Professional retrofitting of mechanical drive systems
- Reliable compatibility testing of existing solutions

Find out more about the
WITTENSTEIN Service Portal



Support hotline

Tel.: +49 7931 493-15800
Fax: +49 7931 493-10200
Email: info@wittenstein-cyber-motor.de

Service hotline

Tel.: +49 7931 493-15900
Fax: +49 7931 493-10903
Email: service@wittenstein-cyber-motor.de

Technical support

Tel.: +49 7931 493-14800
Email: wcm-support@wittenstein.de

Information

Drive selection and sizing

WITTENSTEIN sizing tools – several ways to reach your objectives



Our software portfolio helps you choose the right drive

You can conveniently download dimension sheets and CAD/CAE data, select the best product quickly and easily or design complex kinematic sequences in detail – our software solutions offer various methods of selecting the best, most reliable drive on all axes.



CAD Point

– Your smart catalog

- Performance data, dimension sheets and CAD data for all gearboxes
- Comprehensive documentation for your selection
- Available online, no login required

www.wittenstein-cad-point.de

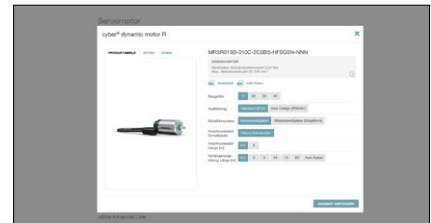

cymex®5

– Calculate on the best

- Detailed calculation of complete drive trains
- Precise simulation of motion and load variables
- Downloadable software for complex designs

www.wittenstein-cymex.de

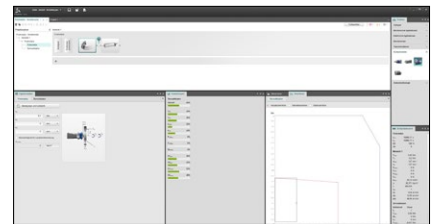

Additional tools



CADENAS

Digital product catalog

- 2D, 3D CAD and CAE models as well as dimension and data sheets for all products
- Multi-CAD /CAE: support for approximately 150 native and neutral formats
- Integration in the CAD POINT WITTENSTEIN solution
- For simplicity, speed and choice in the design process

<https://wittenstein.partcommunity.com>



EPLAN

Data portal catalog

- For reduced project planning work in your electrical design
- Extensive product availability in the EPLAN catalog

<https://dataportal.eplan.com>

WITTENSTEIN Service Portal



The web-based WITTENSTEIN Service Portal supports you throughout the entire life cycle of your WITTENSTEIN product – from installation and commissioning to servicing and/or drive replacement. Here you will find relevant and up-to-date information about your product including explanations, technical data, tutorial videos on assembly and commissioning, documentation, firmware files and the necessary contact details for support. The WITTENSTEIN Service Portal also makes it quick and easy to request replacement products and register returns for inspection or repair.



Fast

You will receive clear information about your product without any need to wait or conduct extensive research.

Simple access

You can access the WITTENSTEIN Service Portal via a desktop PC or mobile device and benefit from the intuitive navigation.

Up to date

You can rest assured that all data, documentation and software is always up to date.

Personal

For further support, you can get in touch directly with the relevant contact person.

Traceable

You can access both the delivered version of the firmware and the latest version.

International

The Service Portal is available in six languages (EN, DE, ES, IT, FR, TR).

Actuator curve (rotary)

Term	Symbol	Unit	Explanation
Continuous torque	M_{S1}	Nm	Continuous torque of the actuator.
Continuous power	P_{S1}	W	Continuous power of the actuator.
DC bus voltage	U_{DC}	V	Voltage at DC bus.
Torque constant	$k_{m \text{ act}}$	Nm/A	Torque constant calculated from torque and the RMS current. $k_m = \frac{M}{I}$
Voltage constant	$k_{e \text{ act}}$	Vs	Voltage constant calculated from peak value of the induced voltage between two terminals and rotation speed for the external driven actuator: $k_e = \frac{\hat{U}_{tt}}{2p n}$
Actuator constant	k_{act}	Nm/ \sqrt{W}	Factor of efficiency calculated from torque and power losses. $k_{mot} = \sqrt{\frac{2}{3}} \times \frac{k_m}{\sqrt{R_{tt}}}$
Ambient temperature	ϑ_u	°C	Maximum permissible ambient temperature without reduced performance (maximum inlet temperature of the coolant for liquid cooling).
Maximum winding temperature	J_{max}	°C	Maximum admissible winding temperature.
Heat transfer resistance	R_{th}	K/W	Heat transfer resistance not to be exceeded for discharge of thermal losses.
Maximum power	$P_{max \text{ act}}$	W	Maximum power in short time operation.
Maximum torque	$M_{max \text{ act}}$	Nm	Maximum torque at maximum current I_{max} .
Maximum current	I_{max}	A	Maximum current rms-value.
Continuous stall torque	$M_{0 \text{ act}}$	Nm	Continuous torque at standstill of the actuator.
Continuous stall current	I_0	A	Continuously permissible current (effective value) leading to the permissible heating of the winding.
No-load speed	$n_{0 \text{ act}}$	rpm	Maximum speed that is reached load-free without field-weakening when operated with U_{DC} .
Rated power	$P_{n \text{ act}}$	W	Continuous permissible power at speed $n_{n \text{ act}}$.
Rated torque	$M_{n \text{ act}}$	Nm	Continuous permissible torque at speed $n_{n \text{ act}}$.
Rated current	I_n	A	Continuously permissible current (effective value) at speed $n_{n \text{ act}}$.
Rated speed	$nn \text{ act}$	rpm	Speed up to which $M_{n \text{ act}}$ is continuously specified.
Brake holding torque	M_d	Nm	Holding torque brake static (at 120°C)
Motor terminal resistance	R_{tt}	Ω	Resistance between two terminals at 20°C.
Motor terminal inductance	L_{tt}	mH	Inductance between two terminals at 20°C.

Term	Symbol	Unit	Explanation
Electrical time constant	t_e	ms	Electrical time constant: $t_e = L_{tt} / R_{tt}$
Number of pole pairs	p		Number of pole pairs of the motor.
Inertia actuator	J_{act}	kgm ²	Mass moment of inertia of the actuator without brake in relation to the application side.
Mass of actuator	m_{act}	kg	Mass of the actuator.
Gear ratio	iG		Ratio of the gear.
Gearbox efficiency	η_G	%	Efficiency of the gear.
Mechanical speed limit S1	$n_{limit,S1}$	rpm	Maximum speed for continuous operation due to mechanical limits.
Max. mechanical speed limit	$n_{limit,Max}$	rpm	Maximum speed for maximum operation due to mechanical limits.

All values specified are subject to specific fluctuations, as the materials used have tolerances both in their properties and in their dimensions. The specified values are mean values, and deviations of $\pm 10\%$ are permissible for torques, currents and speeds.

The actuator curve is calculated with a constant ball screw and gearbox efficiency (if available). When entering mechanical load limits, the usable operating range is restricted. Areas of the maximum characteristic curves determined by the motor that are no longer permissible are shown as dashed lines in the diagram.



cyber motor

WITTENSTEIN cyber motor GmbH · Walter-Wittenstein-Straße 1 · 97999 Igersheim · Germany
Tel. +49 7931 493-15800 · info@wittenstein-cyber-motor.de

WITTENSTEIN Inc. · 1249 Humbracht Circle · Bartlett, IL 60103 · USA
Tel. +1 630 540 5300 · info.cyber-motor@wittenstein-us.com

WITTENSTEIN S.P.A. · Via Giosuè Carducci 125 · 20099 Sesto San Giovanni MI · Italy
Tel. +39 02 241357-1 · info@wittenstein.it

WITTENSTEIN Co., Ltd. · 2-6-6 Shibadaimon Minato-ku · 105-0012 Tokyo · Japan
Tel. +81 3 6680 2835 · sales@wittenstein.jp

WITTENSTEIN (Hangzhou) Co., Ltd. · No. 355 Tianmushan West Road · 311122 Hangzhou · China
Tel. +86 571 8869 5852 / 5851 · info@wittenstein.cn

WITTENSTEIN – one with the future

www.wittenstein-cyber-motor.de